

## Solid-State Flasher

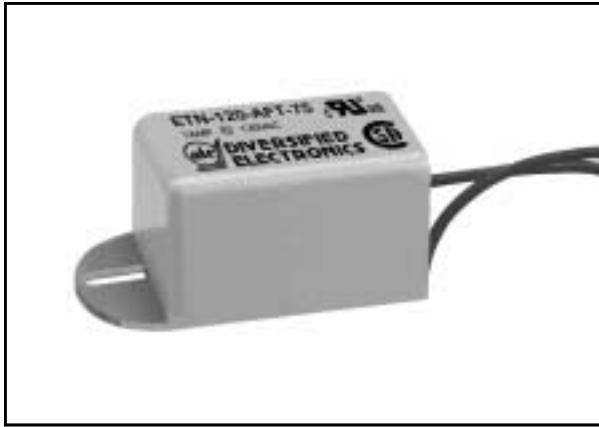

### DIMENSIONS INCHES

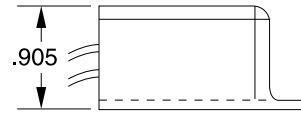
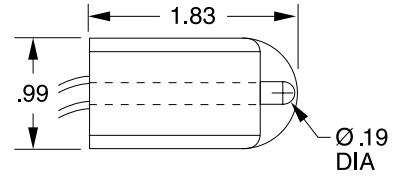

### FEATURES

- Totally Solid-state
- 2-Wire Leads (Series Connection with Load)
- Totally Encapsulated Circuitry
- Molded Case with Built-In Mounting Feature
- High Inrush Capability
- Low Cost
- 1 Amp (Fullwave) and 3 Amp (halfwave) versions

### OPERATION

When supply voltage is applied, the OFF delay (T1) begins. Upon completion of the OFF delay, the load energizes and the ON delay (T2) begins. Upon completion of the ON delay, the load de-energizes and one cycle is complete. This ON/OFF cycling continues until the supply voltage is removed. The OFF delay always equals the ON delay.

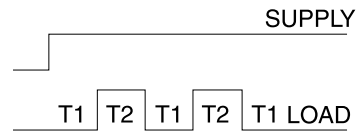

### ORDERING INFORMATION

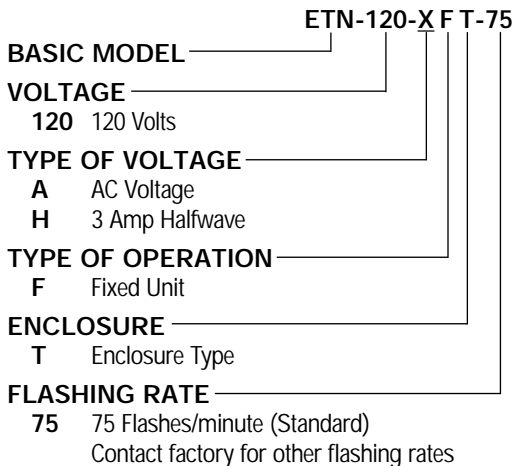

### SPECIFICATIONS

**TIMING ACTION:** Flasher, 50% Duty Cycle  
**TIMING RANGE:** Factory Fixed, (45-150) Flashes per minute  $\pm 20\%$

#### OUTPUT RATING: (SOLID STATE)

1 A Resistive (Fullwave)	10 A Maximum (Inrush) 40 mA Minimum (Hold in Current) 2.5 Volt Drop @ 1 A
3 A Resistive (Halfwave)	10 A Maximum (Inrush) 40mA Minimum (Hold in Current) 1.1 Volt Drop @ 3 Amp

**SUPPLY VOLTAGE:** 120 VAC;  $\pm 15\%$ , 50/60  
**TERMINATIONS:** (2) 6 inch wires, 18 AWG, 300 Volt

**TEMPERATURES**  
 Operate:  $-4^{\circ}$  to  $140^{\circ}$ F ( $-20^{\circ}$  to  $+60^{\circ}$ C) Free Air  
 Storage:  $-40^{\circ}$  to  $185^{\circ}$ F ( $-40^{\circ}$  to  $+85^{\circ}$ C)

**MOUNTING:** No. 8 or No. 10 Screw

**ENCLOSURE:** Polycarbonate Case, Totally Encapsulated for Environmental Protection